

## Geräteaufbau / Equipment construction / Construction d'appareil

### Wachsschmelzgerät / Wax melter / Appareil pour chauffer la cire Typ/Type 20/30

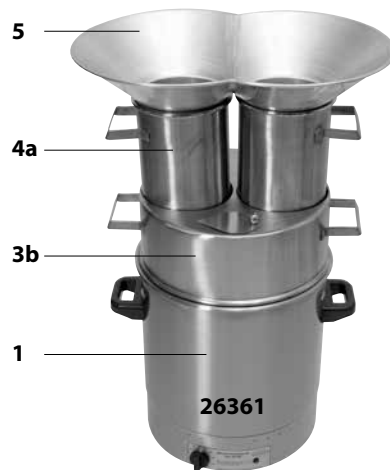

- 1 = Wachsschmelzgerät Typ 20/30 / Wax melter Type 20/30 / Appareil pour fondre la cire, type 20/30
- 2 = Einlegerost Höhe 70 mm / Grids insert height 70 mm / Grille emboîtable hauteur 70 mm
- 3a = Lochdeckel / Hole lid / Couvercle à trou
- 3b = Lochhaube / Hole cover / Calotte à trou
- 4a = Wachsschmelzgefäß / Wax melting pot / Récipient à fondre la cire
- 4b = Seifenschmelzgefäß / Soap melting pot / Récipient à fondre le savon
- 5 = Tropfring / Drip ring / Entonnoir
- 6 = Haltezange / Tongs / Pince

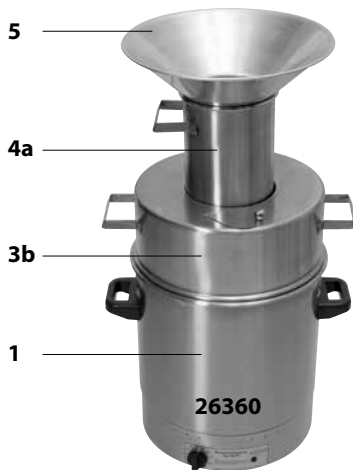